



# Service Bulletin

Enabling Your Ideas

File name: SB0031\_Flushing the Lubrication system.pdf

Rev: 1.0

Date: 11/22/2010

**Product Identification:** All PCNC 1100 Mills and PCNC770 Mills with manual lubrication pumps.

From time to time it may be necessary to flush impurities and or coagulated oil from the lubrication systems of the 1100 mill and the 770 mill.

The main indication that you may have an occluded lubrication system is, that the handle of the oil pump when it is extended out, takes an extremely long time to retract. If this is the case a simple “divide and concur” plan can help in narrowing down the possible occlusion area.

As you can see in the pictures below, disconnecting the one of the distribution lines from the main splitter, and capping the splitter port (with a finger or a 8mm pipe threaded plug) will isolate the problem to one of the two distribution lines. You can expect the handle of the manual pump to retract more quickly when the clear line is the attached line.

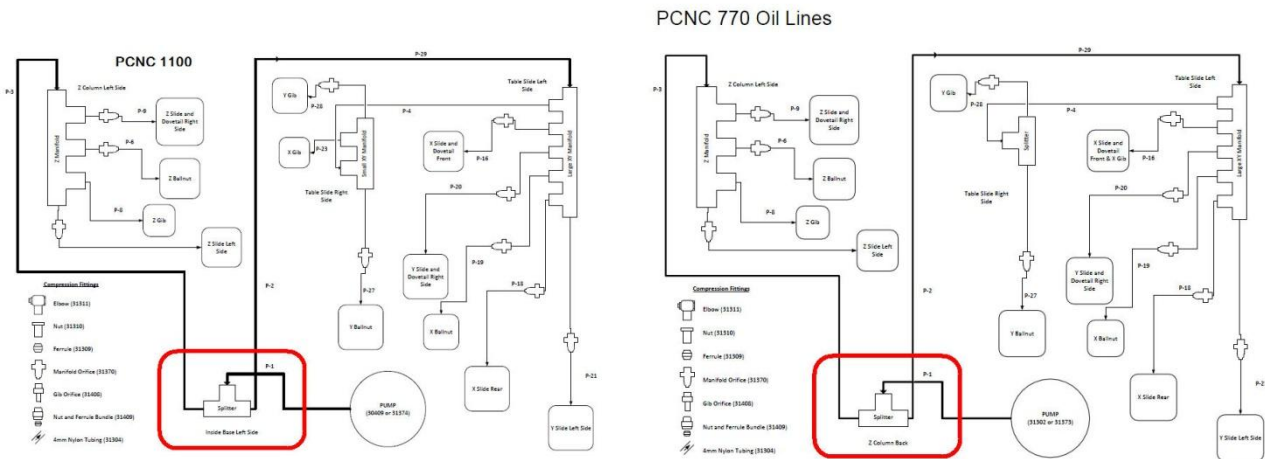

After you have determined what line has the occlusion (it could be both distribution lines are occluded), then the next step will be to drain as much oil from the pump and the lines by fist draining the pump, and then disconnecting both lines from the splitter and letting oil drip out (this may be helped by slightly loosening the easily accessible fittings, and raising the air temperature of the area that the machine is kept). After about an hour of draining, re tighten the loosened fittings and make sure that the occluded line is hooked back up to the splitter, and the free line (if applicable) is disconnected and it’s port is blocked.

Now fill the oil pump with a solvent (we recommend WD-40) and repeatedly pump the lubrication lines until the handle of the oil pump retracts freely within 7 seconds.

Once the handle is moving freely again, reconnect all the distribution lines and be sure to pump more solvent into the all of the lines, and let the solvent sit in the lubrication lines overnight.

The next day fill the lubrication pump back up with new, clean way oil (we recommend Perkins Perlube WL-68 ) and pump a dozen times to distribute the new oil.