



Tormach® has developed an industrial robot arm to add to our line of CNC mills, lathes, plasma tables, and routers. The robot is controlled via PathPilot™, Tormach's award-winning CNC user interface. The underlying trajectory planning and motion control is handled by ROS, an open-source robot operating system with tens of thousands of active developers worldwide. Access to the underlying code is provided to all customers, allowing participation in the range of research opportunities offered by the ROS ecosystem.

KEY FEATURES

PathPilot™ user interface

- PathPilot™ is user-friendly, making programming easier and faster to learn. Learn how to create robot programs with minimal effort.
- Similar layout to PathPilot interface on other Tormach® CNC machines. Familiarity with PathPilot on one piece of equipment allows users to go between Tormach® CNC equipment even more intuitively.
- Web-based user interface simulator (hub.pathpilot.com)

Powered by ROS (Robot Operating System)

- The most popular platform for robotics research (over 4,000 academic papers cite "[ROS: an opensource Robot Operating System](#)" (Quigley et al., 2009))
- Vibrant community development effort
(For detailed statistics, see <http://download.ros.org/downloads/metrics/metrics-report-2018-07.pdf>)

Robust industrial hardware

- The Tormach robot is an industrial tool that's been made exceptionally easy to use. It utilizes solid metal casting, servo motors and drives, and harmonic gear reducers.

Robot programs are written in Python

- For beginners or for writing simple programs, PathPilot includes an intuitive, graphical, block-based programming system called "conversational."
 - The visual block-based programs are actually Python underneath, so when your program is ready for the next level, you can continue coding directly in Python without rewriting from scratch
- For users familiar with Python, robot programs are easy to understand and modify
- Python users can easily extend robot programs to interact with the file system or the outside world
 - For example:
 - Import time, time.sleep(.5) to delay an action 0.5 seconds
 - Import csv, with open('eggs.csv', 'rb') as csv file to read in position values from a csv file, or write out values to a csv file
 - Import usb.core, usb.util, more complex python code here to read data from a USB scale to use the robot to measure the weight of an object



*Table not included.

TECHNICAL SUPPORT

Tormach offers remote technical support via email, phone, and video chat.

Support is limited to mechanical issues and software issues when the machine is controlled via the default software installation. Customers are free to modify the source code in a sandbox, but ROS research and code modification is outside the scope of Tormach's free technical support. We are happy to consult with customers that require ROS support or training, although we won't do consulting engineering or software development.

SPECIFICATIONS

WEIGHT	146 lbs. (65 kg)		
PAYLOAD	13 lbs. (6 kg)		
REACH	38 in. (975 mm)		
JOINT RANGES		JOINT SPEEDS	
JOINT 1	± 170°	JOINT 1	150° s-1
JOINT 2	± 135° to -100°	JOINT 2	112.5° s-1
JOINT 3	± 155° to -120°	JOINT 3	150° s-1
JOINT 4	4° ± 150°	JOINT 4	204.5° s-1
JOINT 5	5° ± 120°	JOINT 5	225° s-1
JOINT 6	3° ± 360°	JOINT 6	360° s-1
REPEATABILITY	± 0.5 MM / 0.020"		
DEGREES OF FREEDOM	6 rotating joints		
CONTROL BOX SIZE (W × H × D)	26" × 32" × 14" (650 mm × 820 mm × 360 mm)		
DIGITAL INPUTS	12		
DIGITAL OUTPUTS	12		
I/O POWER SUPPLY	24 Volt 2 Amp		
PROGRAMMING	Teachmode programming through PathPilot™ GUI, Python		
IP RATING	IP65		
POWER SUPPLY	Single-Phase 200 - 240 Vac, 50 - 60 Hz, 20 A breaker		
TOOL FLANGE	ISO 9409-1-50-4-M6		

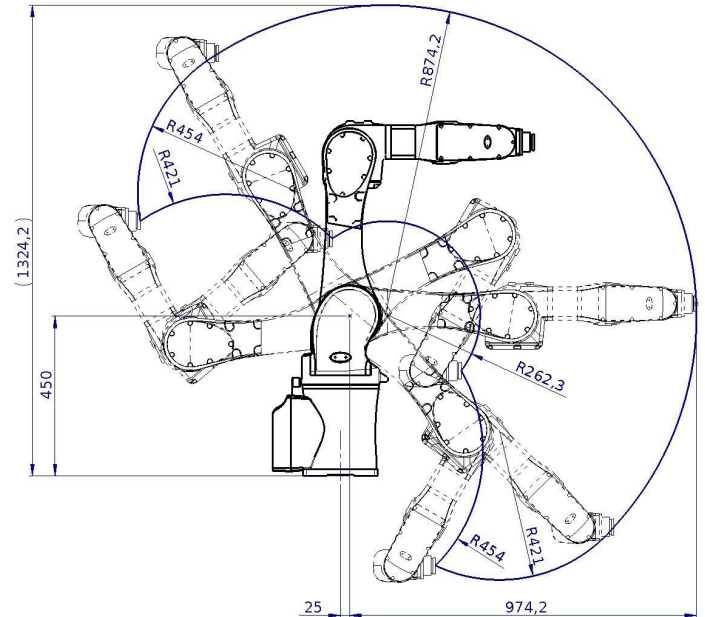

PRODUCT ROADMAP

Tormach will offer software upgrades at no cost when they become available. In addition, Tormach is working on developing the following items and will make them available after the initial product release:



- Computer vision/visual servoing
- Integration with Mimic/Maya/Blender animation software for robot programming
- ZA2, a small trainer robot for under \$5,000 that will work on the same user interface/operating system

VIDEOS

ZA6 Robot QuickTips Python Programming:
youtu.be/xPSEzN2nErg

Uncrating and Demo of ZA6 Robot
by Big T's Chop Shop:
youtu.be/hdVduR-lRj0



*All package prices subject to change without notice.

©2023 Tormach®. Specifications subject to change without notice.
tormach.com | ZA6 Spec Sheet (0523)